



## 4FT LED BATTEN 40W 3CCT IP20

### VBLB-4-40W-CCT



Our 4 foot, 40W, 100 Series LED Batten is an excellent indoor choice, offering application versatility across many industries including the option of a linear industrial look in offices or even supermarkets. With a smooth, even light distribution, the polycarbonate build provides a sleek contemporary design. 3CCT allows you to select the best kelvin temperature to suit the space - 3000K, 4000K or 5700K, the choice is yours! Including multiple wiring terminals and safety chains, installation is simple and safe. Includes a 40,000 hour lifespan and 3 year warranty.

### Features & Benefits

- Sleek, contemporary design
- Equipped with high efficiency EPISTAR LED chips
- Polycarbonate housing
- Multiple wiring terminals for easy installation
- Includes installation safety chains
- Smooth, even light distribution
- 40,000 hours lifespan
- 3 years warranty



# 4FT LED BATTEN 40W 3CCT IP20

VBLB-4-40W-CCT

## Specifications

SKU	VBLB-4-40W-CCT
Luminaire efficacy	115 lm/W
EAN	9340994021737
Light Colour	3CCT
Wattage	40 W
Lumen output	4600 lm
IP rating	20
CRI	80
Beam Angle	120 Degrees
Length	1203 mm
Width	71 mm
Height	64 mm
Lifespan	40000 Hours
Warranty	3 Years
Dimmable	Non-Dimmable
Mounting type	Surface
LED source	SMD
Material	Polycarbonate Housing
Lamp Type	LED
Input voltage	220-240V / 50Hz
Diffuser	Frosted
Wiring method	Hardwire
Weatherproof	Indoor Use Only
Working temperature	-20 to 45 degrees
Box Qty	12
Pallet Qty	252



## Dimensional Drawings

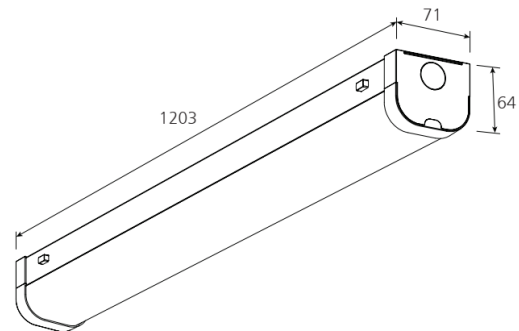

Photometric information available upon request.