



VBLHB-A1-150W-PA-CCT



VIBE Power Adjustable High Bays are the ultimate lighting solution for applications such as Warehousing & Logistics, Gymnasiums and more. Adjust the power on this model from 80W-150W to provide the exact light output required. Utilize the optional built in remote controlled Microwave Sensor (Optional) to further reduce power consumption in low traffic areas.

Features & Benefits

- Ultra slim design
- Super bright LED highbay - 170LM/W
- Power adjustable: 80W-150W
- 4000K/5000K Colour Temperature Switchable
- Constructed from lightweight and durable die-cast aluminium, with an extra tough anti-corrosive coating
- Polycarbonate optic lens with 120° beam spread
- Replaces traditional 250W or 400W Metal Halide highbays
- Installation options: Hook or Bracket Mount
- Supplied with safety chain, eye bolt and 1.5M flex & plug
- Built in Remote Controlled PIR Sensor (Optional)
- 50,000 hour lifespan
- 5 year warranty



Specifications

SKU	VBLHB-A1-150W-PA-CCT
Luminaire efficacy	170LM/W lm/W
EAN	9340994031545
Wattage	150 W
Lumen output	25500 lm
IP rating	IP65
IK Rating	IK08
CRI	80
Beam Angle	100 Degrees
Trim colour	Black
Diameter	275mm mm
Height	124 mm
Lifespan	50000 Hours
Warranty	5 Years
Dimmable	Dimmable
Mounting type	Hook,Suspended
LED source	SMD
Material	ALUMINIUM
Lamp Type	LED
Dimming	0-10V
Input voltage	240 Volt AC 50HZ
Wiring method	Flex & Plug
Weatherproof	Weatherproof
Working temperature	-40° ~ 50° C
Box Qty	1
Kelvin	4000/5000K
Power Adjustable	Yes



Dimensional Drawings

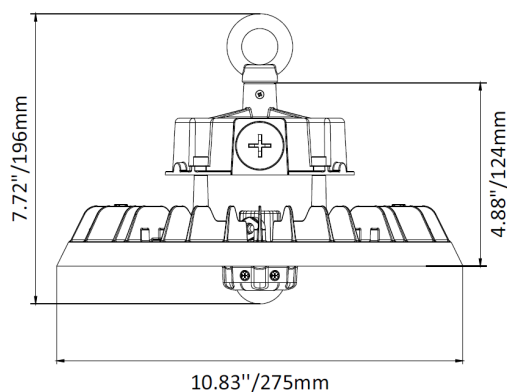

Photometric information available upon request.