



## VBLHB-A1-150W-PA-CCT



VIBE Power Adjustable High Bays are the ultimate lighting solution for applications such as Warehousing & Logistics, Gymnasiums and more. Adjust the power on this model from 80W-150W to provide the exact light output required. Optional remote controlled PIR Sensor available to further reduce power consumption in low traffic areas.

### Features & Benefits

- Ultra slim design
- Super bright LED highbay - 170LM/W
- Power adjustable: 80W-150W
- 0-10V Dimmable
- 4000K/5000K Colour Temperature Switchable
- Constructed from lightweight and durable die-cast aluminium, with an extra tough anti-corrosive coating
- Polycarbonate optic lens with 100° beam spread
- Replaces traditional 250W or 400W Metal Halide highbays
- Installation options: Hook, chain or Bracket Mount
- Supplied with eye bolt and 1.5M flex & plug
- Built in Remote Controlled PIR Sensor (Optional)
- Optional DALI dimmable converter
- 50,000 hour lifespan
- 5 year warranty inclusive of 12 month labour warranty



## Specifications

<b>SKU</b>	VBLHB-A1-150W-PA-CCT
<b>Luminaire efficacy</b>	170LM/W lm/W
<b>EAN</b>	9340994031545
<b>Wattage</b>	150 W
<b>Lumen output</b>	25500 lm
<b>IP rating</b>	IP65
<b>IK Rating</b>	IK08
<b>CRI</b>	80
<b>Beam Angle</b>	100 Degrees
<b>Trim colour</b>	Black
<b>Diameter</b>	275mm mm
<b>Height</b>	124 mm
<b>Lifespan</b>	50000 Hours
<b>Warranty</b>	5 Years
<b>Dimmable</b>	Dimmable
<b>Mounting type</b>	Hook,Suspended
<b>LED source</b>	SMD
<b>Material</b>	ALUMINIUM
<b>Lamp Type</b>	LED
<b>Dimming</b>	0-10V
<b>Input voltage</b>	240 Volt AC 50HZ
<b>Wiring method</b>	Flex & Plug
<b>Weatherproof</b>	Weatherproof
<b>Working temperature</b>	-40° ~ 50° C
<b>Box Qty</b>	1
<b>Kelvin</b>	4000/5000K
<b>Power Adjustable</b>	Yes



## Dimensional Drawings

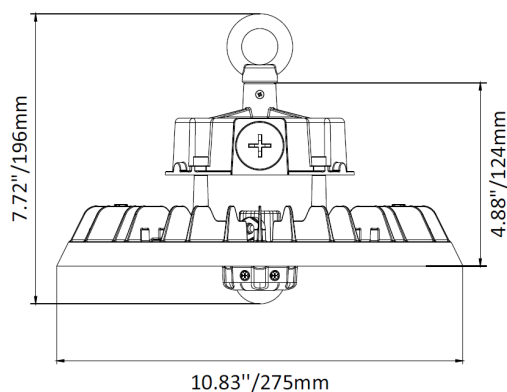

*Photometric information available upon request.*

*12 Month labour warranty*