



VBLHB-A1-240W-PA-CCT



VIBE Power Adjustable High Bays are the ultimate lighting solution for applications such as Warehousing & Logistics, Gymnasiums and more. **These quality fittings are able to operate low at a -40deg temperature - perfect for cool rooms and freezers.**

Adjust the power on this model from 150W-240W to provide the exact light output required. Optional remote controlled PIR Sensor available to further reduce power consumption in low traffic areas.

Features & Benefits

- Ultra slim design
- Super bright LED highbay - 170LM/W
- Power adjustable: 150W-240W
- 0-10V Dimmable
- 4000K/5000K Colour Temperature Switchable
- Constructed from lightweight and durable die-cast aluminium, with an extra tough anti-corrosive coating
- Polycarbonate optic lens with 100° beam spread
- Replaces traditional 250W or 400W Metal Halide highbays
- Installation options: Hook, chain or Bracket Mount
- Supplied with eye bolt and 1.5M flex & plug
- Built in Remote Controlled PIR Sensor (Optional)
- Optional DALI dimmable converter
- 50,000 hour lifespan
- 5 year warranty inclusive of 12 month labour warranty



Specifications

SKU	VBLHB-A1-240W-PA-CCT
Luminaire efficacy	170LM/W lm/W
EAN	9340994031651
Wattage	240 W
Lumen output	40800 lm
IP rating	IP65
IK Rating	IK08
CRI	80
Beam Angle	100 Degrees
Trim colour	Black
Diameter	305 mm
Height	200 mm
Lifespan	50000 Hours
Warranty	5 Years
Dimmable	Dimmable
Mounting type	Hook,Suspended
LED source	SMD
Material	ALUMINIUM
Lamp Type	LED
Dimming	0-10V
Input voltage	220-240V / 50Hz
Wiring method	Flex & Plug
Weatherproof	Weatherproof
Working temperature	-40° ~ 50° C
Box Qty	1
Pallet Qty	99
Kelvin	4000/5000K
Power Adjustable	Yes



Dimensional Drawings

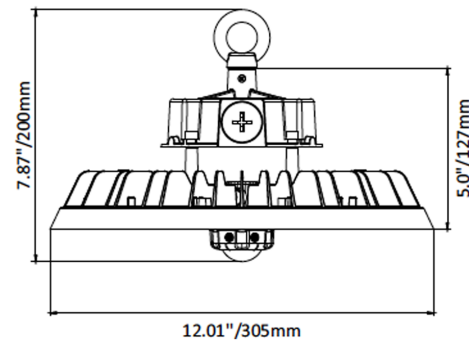

Photometric information available upon request.

12 Month labour warranty