



LED SEMI CUT OFF WALL PACK 60W BRONZE 5000K

VBLWPK-60W-5-50



The Vibe LED Semi Cut Off Wall Pack, featuring a durable die-cast aluminum housing with a glass lens and bronze finish. Corrosion-resistant and equipped with SMD LED chips, this wall pack is perfect for public spaces, commercial, and industrial applications, ensuring reliable and efficient lighting.

Features & Benefits

- The integrated wall pack features a sturdy die-cast aluminum housing with glass lens
- Bronze housing
- Corrosion resistant
- Equipped with SMD LED chips
- Suitable for public spaces, commercial and industrial applications
- IP65 rated
- 50,000 hour lifespan
- 5 year warranty

LED SEMI CUT OFF WALL PACK 60W BRONZE 5000K

VBLWPK-60W-5-50

Specifications

SKU	VBLWPK-60W-5-50
Luminaire efficacy	120.9 lm/W
EAN	9340994028385
Light Colour	5000
Wattage	60 W
Lumen output	7258 lm
IP rating	65
IK Rating	8
CRI	70
Beam Angle	120 Degrees
Length	416 mm
Width	239 mm
Height	223 mm
Lifespan	50000 Hours
Warranty	5 Years
Dimmable	Non-Dimmable
Mounting type	Surface
LED source	SMD
Material	Aluminum
Lamp Type	LED
Input voltage	220V-240V AC 50HZ
Wiring method	Hardwire
Weatherproof	Weatherproof
Working temperature	-92



Dimensional Drawings

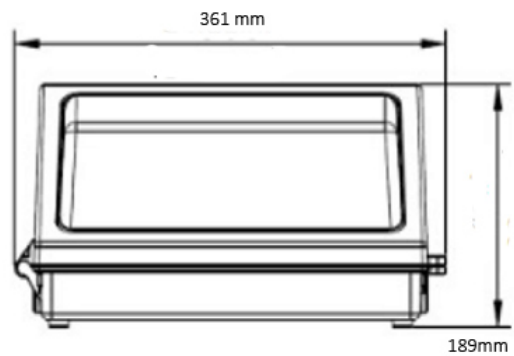

Photometric information available upon request.